



PowerWadi

Smart Power. Smarter Control.

WADI VFD



**Torque
Boost**



**RS-485
Modbus**



**PID
Control**



OVERVIEW



High-performance variable frequency drive with best versatile integrated and versatile capabilities.

APPLICATIONS



Versatile and suitable for multi-application use

KEY FEATURES



- Dynamic speed regulation
- Robust protection features
- User-friendly interface

SPECIFICATIONS



Power Range:
0.75 kW – 500 kW

PowerWadi – WADI VFD 0.75 – 37 KW

Smart Power. Smarter Control.



Product Overview

- Self-developed new generation of general-purpose VFD, which can be used to control
- asynchronous AC induction motors
- Adopt space voltage vector control technology, use DSP control system, strengthen product reliability and stability
- V/F Control , Sensor-less Vector Control (SVC)
- Automatic torque boost and slip compensation
- Fast acceleration and deceleration performance
- 150% torque at 0.5Hz
- Provide precise speed control <math><0.5\%</math>
- Acceptable wide input voltage from 200V ~ 440V
- Conformal coating to withstand harsh environment
- Built-in RS-485 MODBUS communication
- Standard potentiometer and support external keypad

PowerWadi – WADI VFD

Smart Power. Smarter Control.

Applications

Industrial Applications

- Conveyor Belt Speed Control
- Extruders and Mixers
- Industrial Ovens and Furnaces
- Cooling Towers
- Textile Machinery
- Paper & Pulp Processing Equipment

Commercial & Building Sector

- Chiller Systems
- Cooling & Heating Circulation Pumps
- Escalators and Moving Walkways
- Elevator Motor Control
- Building Automation and Energy Optimization

Water & Wastewater

- Booster Pumps
- Irrigation Systems
- Aeration Blowers
- Clarifier Drives
- Sludge Handling Equipment

Oil & Gas / Energy Sector

- Drilling Rigs
- Pipeline Pumping Systems
- Burner Management Fans
- Refinery Blowers and Pumps

Applicable Industries

Food Packaging Machinery / Forging Machine Tool / Chemical Fiber Equipment / Fan / Metallurgical Equipment
Machine Tool / Drawing Machine / Pumping Unit / Brick Machine / Plastic Extruding Machine / Compressor



Compressor



Sewage processor



Injection molding machine



Crusher



Blender



Forging machine

PowerWadi – WADI VFD

Outstanding Drive Performance

Unit with same rating and same setting (Acceleration 0.1 sec, deceleration 1 sec) Performance Comparison

Acceleration Waveform

Pioneer

Other Brand

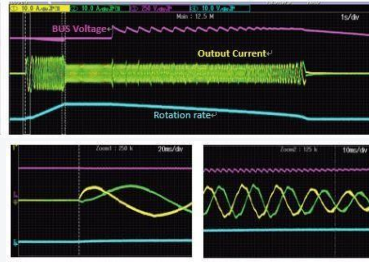

Actual Acceleration 1.06s
Short acceleration time,
precise current response

Actual Acceleration 1.21s
Long acceleration time,
slow current response

Deceleration Waveform

Pioneer

Other Brand

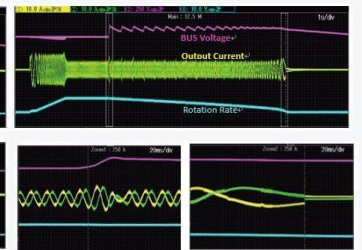
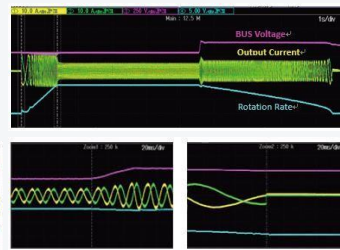

Actual Deceleration 3.94s
BUS voltage stable &
straight, waveform smooth

Actual Deceleration 5.25s
BUS voltage oscillates, current
fluctuates, motor noise

Waveform Performance for sudden loading and sudden unloading at 150% load

Pioneer

Other Brand

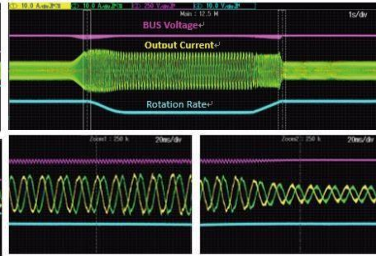
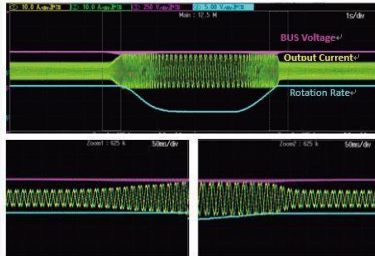

Fast dynamic response,
perfect current limiting

Slow dynamic response,
oscillate waveform, current
fluctuates

Waveform Performance while sudden power failure

Pioneer

Other Brand

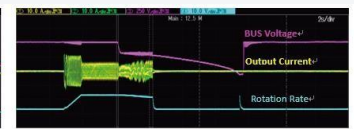
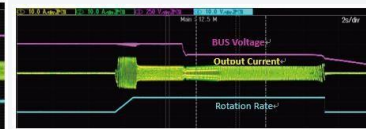

At power failure, unit runs
for 10s, motor winds down

At power failure, unit runs
for 3s, UV alarm motor
stops freely

Flexible Installation

Provide high configuration flexibility and improve installation efficiency.



High Starting Torque

150% starting torque with a low speed control of 0.5Hz provides outstanding machine stability, suitable for low loading applications.

Current Control for optimized lifecycle

After installing the VFD, startup current of the motor will not increase, which not only saves the cost, but also prolongs lifecycle

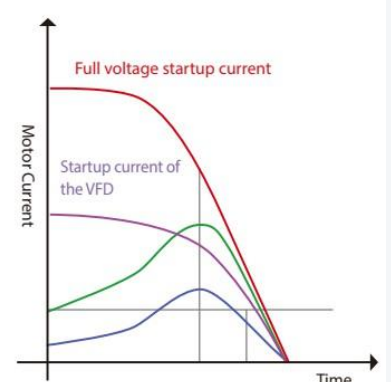
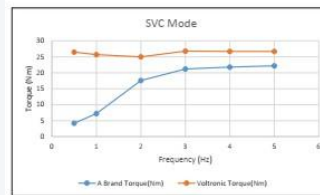
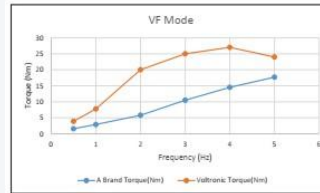
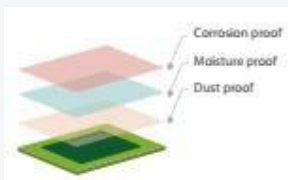

Diagram of changing current from startup to stop

Conformal Coating

Ensures operation stability and safety in critical environment.



Built-in Power Supply for Sensor

Separate power supply not required because it's already built in 10Vdc and 24Vdc output for external sensors.



Multiple Programmable I/O Terminals

Pioneer provides multiple programmable digital and analog input and output terminals to meet diverse applications.



Seamless Installation

Support seamless side-by-side installation, saving installation space.



Detachable Operation Keypad

The keypad supports the one-click setting of industry parameters and can be pulled out for remote operation



VFD Model Naming Rules

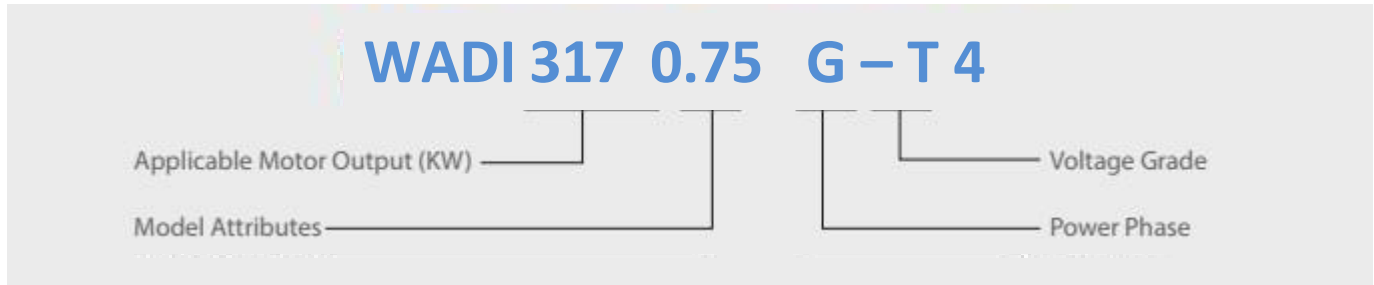

Model Attributes	G: G type model (heavy load model): 150% overload for 60s, 180% overload for 6s
	P: P type model (general-purpose model): 120% overload for 60s, 150% overload for 6s
Power Phase	S: Single phase
	T: Three phase
Voltage Grade	4: 380V 2: 220V

Note: Some models support attribute switching between G/P models, take 15KW as an example: Users can switch the 15KW G type to 18.5KW P type by setting.

Models Selection Guide — Single Phase 220V

Model	KVA	Input A	Output A	Motor kW	HP
WADI 317-0.75G-S2 Small / Small-E / -E / S2	1.5	8.2	4	0.75	1
WADI 317-1.5G-S2 Small / Small-E / -E / S2	3	14	7	1.5	2
WADI 317-2.2G-S2-E / S2	4	23	9.6	2.2	3
WADI 317-3.7G-S2	5.9	32	17	3.7	5
WADI 317-5.5G-S2	11	45	25	5.5	7.5

* -E is the economic model without brake unit, RS-485 communication port, remote panel jack and output relay.

Models Selection Guide — Three Phase 380V

Model	KVA	Input A	Output A	Motor kW	HP
WADI 317-0.75G-T4-Small / 0.75G/1.5P-T4	1.5	3.4	2.1	0.75	1
WADI 317-1.5G-T4-Small / 1.5G/2.2P-T4	3	5	3.8	1.5	2
WADI 317-2.2G-T4-Small / 2.2G/3.7P-T4	4	5.8	5.1	2.2	3
WADI 317-3.7G/5.5P-T4	6	10.5	9	3.7	5
WADI 317-5.5G/7.5P-T4	11	13.9	13	5.5	7.5
WADI 317-7.5G/11P-T4	15	18.9	17	7.5	10
WADI 317-11G/15P-T4	30	27.8	25	11	15
WADI 317-15G/18.5P-T4	37	37.9	32	15	20
WADI 317-18.5G/22P-T4	44	46.7	37	18.5	25
WADI 317-22G/30P-T4	60	55.6	45	22	30
WADI 317-30G/37P-T4	52	57	60	30	40
WADI 317-37G/45P-T4	63	69	75	37	50

PowerWadi – WADI VFD

Smart Power. Smarter Control.

Product Specification

Model	0.75KW-37KW
INPUT	
Input Voltage	AC,1PH,220V(-15%)~240V(+10%) AC,3PH,380V(-15%)~440V(+10%)
Rated Frequency	50/60 Hz
Frequency Range	±5% (47.5 ~ 63Hz)
OUTPUT	
Output Voltage	0- Input Voltage
Maximum Output Frequency	0.1 ~ 500HZ
Output Power	Please refer to Rated Parameter table
Output Current	Please refer to Rated Parameter table
BASIC PARAMETERS	
Highest frequency	Vector control: 0 ~ 500Hz
	V/F control: 0 ~ 500Hz
Carrier frequency	0.8KHz~8KHz
	Adjusted automatically according to the load characteristics
Input frequency resolution	Digital setting: 0.01Hz
	Analog setting: Highest frequency×0.025%
Control mode	Open-loop vector control (SVC) V/F control
Starting torque	0.5Hz/150% (SVC)
Adjustable speed ratio	1 : 100 (SVC)
Speed control accuracy	±0.5% (SVC)
Overload capability	150% of rated current: 60 seconds
	170% of rated current: 12 seconds
	190% of rated current: 1.5 seconds
Torque boost	Auto torque boost; Range of manual torque boost 0.1%~30.0%
V/F curve	Three types: Linear, Multi-point, square curve
	(1.2 power, 1.4 power, 1.6 power, 1.8 power, 2 power)
V/F separation	Full separation, Half separation
Acceleration and deceleration time	Linear and S-curve acceleration and deceleration modes available. The range of acceleration and deceleration time is 0.0~6500.0s.
DC braking	DC braking frequency: 0.00Hz ~ Maximum frequency
	Braking time: 0.0s~36.0s
	Braking current value: 0.0%~100.0%
JOG control	JOG frequency range: 0.00Hz ~ Maximum frequency (5Hz in default). JOG acceleration and deceleration time: 0.0s~6500.0s.
Built-in PID	Simplify the establishment of a closed-loop control system
Automatic voltage regulation (AVR)	Keep the output voltage in stable when the grid voltage fluctuates.
Stall prevention from overvoltage and overcurrent	The current and voltage are limited automatically during operation to prevent frequent tripping due to over-current and over-voltage.
Rapid current limit	Reduce the risk of over-current faults to keep VFD operated normally.
Torque limit and control	Limit the torque automatically during operation to prevent frequent tripping due to over-current.

PowerWadi – WADI VFD

Smart Power. Smarter Control.

Model	0.75KW-37KW
SPECIAL FEATURES	
Deceleration to stop	In case of power loss, the energy from load feedback is used to compensate and decelerate the motor until standstill, to prevent mechanical damage.
Rapid current limit	Reduce the risk of over-current faults to keep VFD operated normally.
Timer control	Setting range: 0.0Min ~ 6500.0Min
Communication	Modbus
INPUT/OUTPUT	
Command source	Operation panel, control terminal and serial communication port
Frequency source	Digital setting, Analog voltage setting, Analog current setting, Pulse setting and Serial port setting.
Auxiliary frequency source	5 options to provide flexible auxiliary frequency fine-tuning and frequency synthesis.
Input terminals	5 digital input terminals, one of which supports high-frequency pulse input up to 50kHz (MINI models: 4 digital input terminals, one of which supports high-frequency pulse input up to 50kHz)
	1 analog input terminal supporting 0 ~ 10V voltage input or 0 ~ 20mA current input
	1 rotary potentiometer analog input
Output terminals	1 high-speed pulse output terminal supporting 50kHz step-wave signal output
	1 relay output terminal
	1 analog output terminal supporting 0~20mA current output or 0~10V voltage output

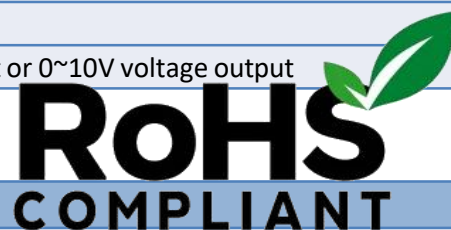

General Specification

DISPLAY BUTTONS	
Keypad	standard keypad
LED display	Display parameters
Key lock and function selections	It allows users to partially or fully lock the keys or define operated range for partial keys to prevent misoperation
Protective function	Motor short-circuit detection at power-on, output phase loss protection, over-current protection, over-voltage protection, under-voltage protection, overheat protection, overload protection and etc.
ENVIRONMENT	
Storage temperature	-20°C ~ 60°C
Operation temperature	-10°C ~ 50°C (If temperature is higher than 40°C, the output capacity will be derated 1% per 1°C increase)
Storage humidity	< 95% RH
Operation humidity	< 95% RH
Noise Level	50dBA max.
STANDARD	
Safety	Standards:IEC 61800-5-1
INTERACE	
Communication Port	RS-485

PowerWadi – WADI VFD

Smart Power. Smarter Control.

Dimensions (mm)

- 1. Opeartion keyboard
- 2. Cabinet
- 3. Bottom installation hole
- 4. Input-output hole
- 5. Flip cover
- 6. Front cover

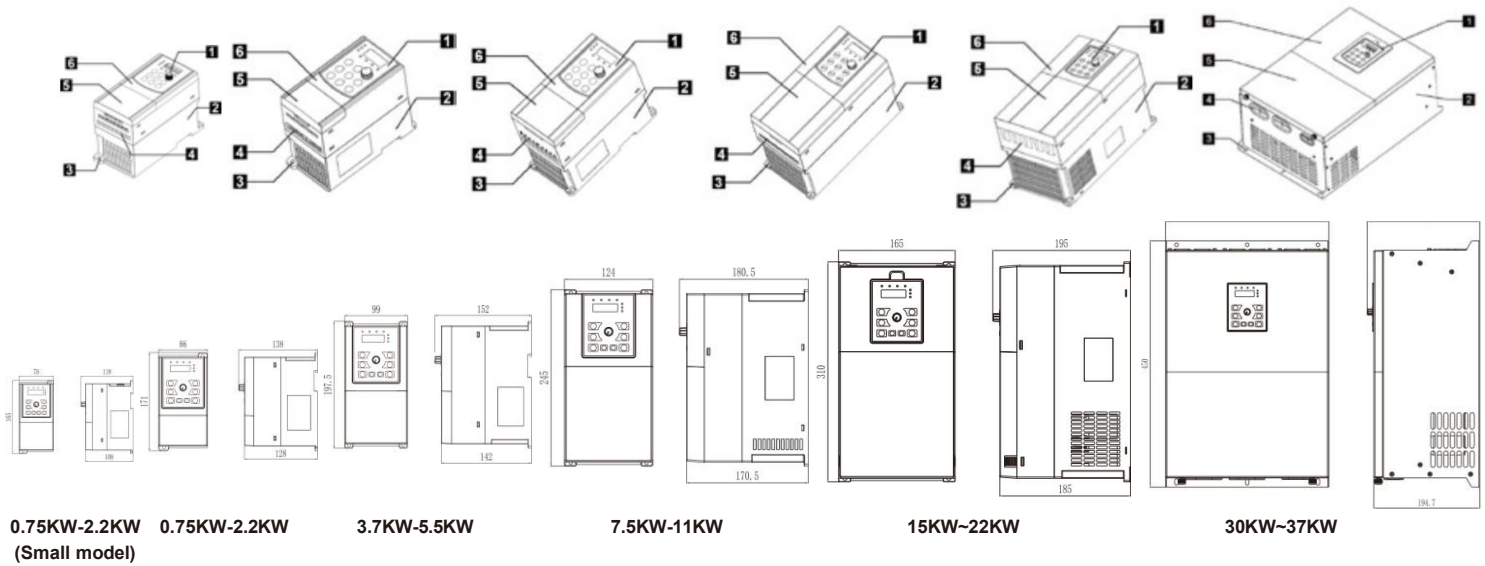

VFD 0.75W-37KW Installation Dimension

MODEL	Instillation Position(mm)		Overall Dimensions(mm)			Instillation Position (mm)	Weight (KG)
	A	B	H	W	D		
WADI 317- 0.75G-S2-Small	62	152	165	78	118	5.5	0.7
WADI 317- 1.5G-S2-Small							
WADI 317- 0.75G-T4-Small							
WADI 317- 1.5G-T4-Small							
WADI 317- 2.2G-T4-Small	67.3	157.5	171	86	138	5.2	1
WADI 317- 0.75G-SP2							
WADI 317- 1.5G-S2							
WADI 317- 2.2G-S2							
WADI 317- 0.75G/1.5P-T4	85	184	197.5	99	152	5.2	1.5
WADI 317- 1.5G/2.2P-T4							
WADI 317- 2.2G/3.7P-T4							
WADI 317- 3.7G/5.5P-T4							
WADI 317- 3.7G-S2	106	233	245	124	180	5.2	2.5
WADI 317- 5.5G-S2							
WADI 317- 7.5G/11P-T4							
WADI 317- 11G/15P-T4							
WADI 317- 15G/18.5P-T4	147	298	310	165	195	5.5	5.5
WADI 317- 18.5G/22P-T4							
WADI 317- 22G/30P-T4							
WADI 317- 30G/37P-T4							
WADI 317- 37G/45P-T4	260	433.5	450	300	207	6.5	15.5

PowerWadi – WADI VFD

Smart Power. Smarter Control.

Wiring Diagram

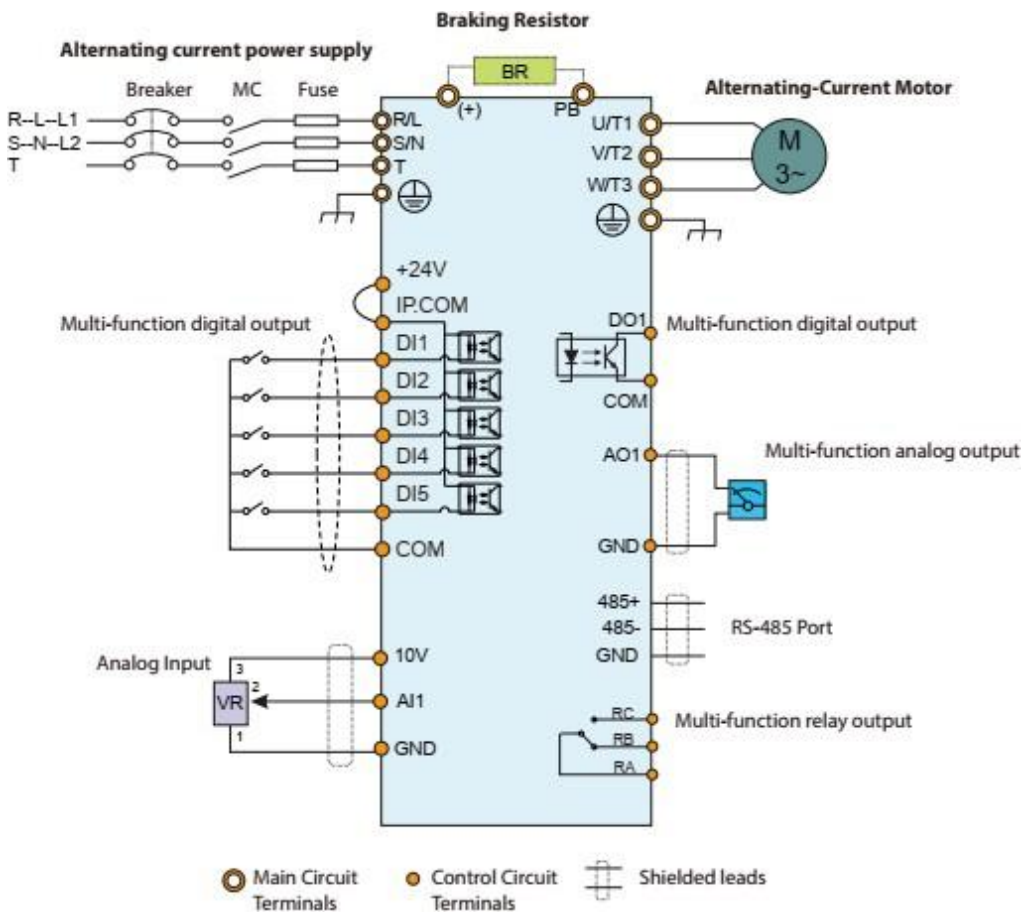
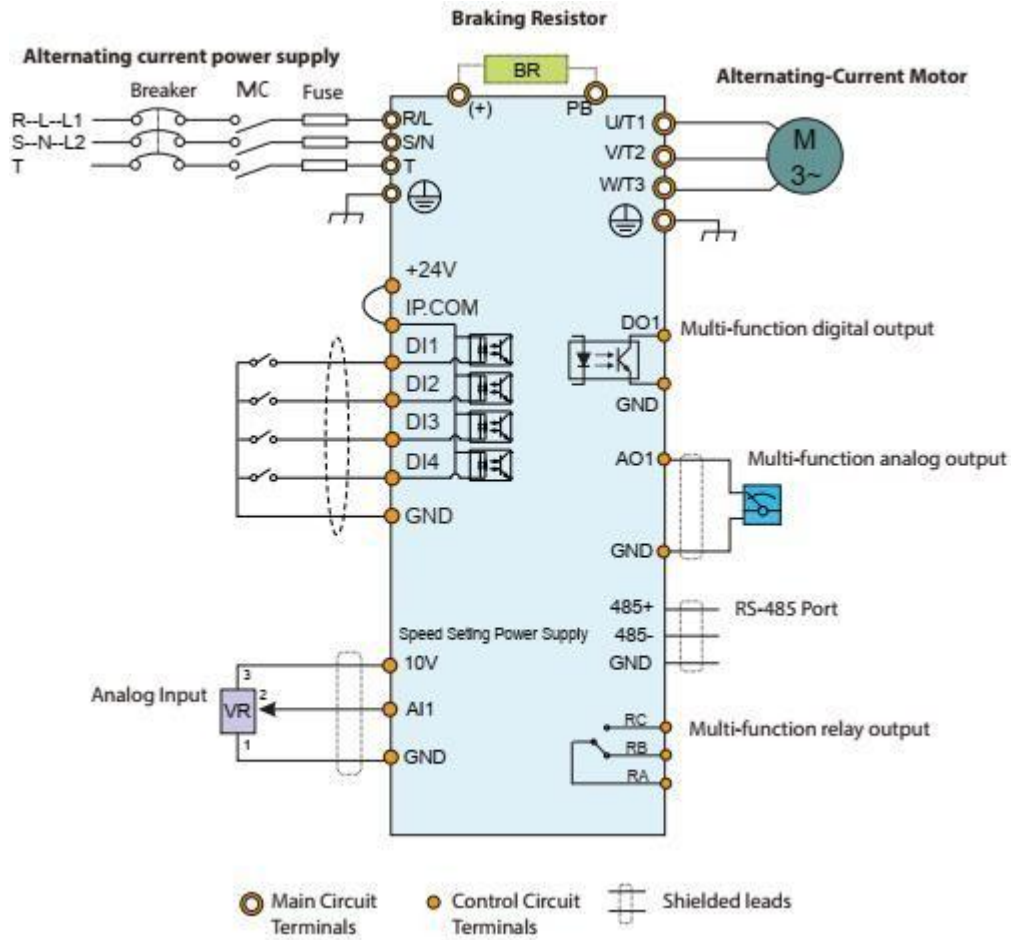

Control Terminal Location and Function Description

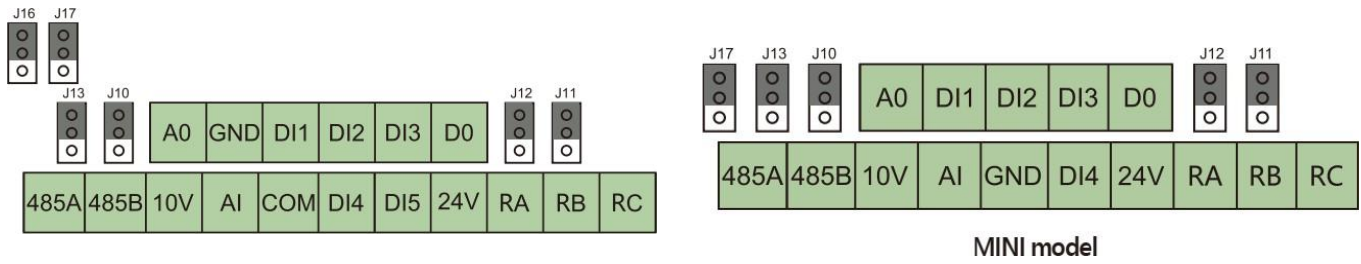

Category	Terminal label	Name	Description
Communication	RS485A	RS485 COM port	RS485 differential signal positive terminal
	RS485B		RS485 differential signal negative terminal
Analog input	AI1	Analog input terminal 1	Analog voltage/current input
Analog output	AO1	Analog output terminal 1	Analog voltage/current output
Digital input	DI1	Digital input terminal 1	Normal digital input
	DI2	Digital input terminal 2	Normal digital input
	DI3	Digital input terminal 3	Normal digital input
	DI4	Digital input terminal 4	Normal digital input(MINI model : Normal digital output/high frequency pulse output)
	DI5	Digital input terminal 5	Normal digital input/high frequency pulse input (N/A for MINI model)
Digital output	DO	Digital output terminal	Normal digital output/high frequency pulse output
Power supply	10V	+10V power supply	Provide +10V power supply
	GND	+10V power ground	Reference ground for analog signal and +10V power supply (MINI model: shared port for GND and COM)
	24V	+24V power supply	Provide +24V power supply
	COM	+24V power ground	Reference ground for analog signal and +24V power supply (N/A for MINI model)
Relay output	RA/RB	Relay output	Normally closed terminal
	RA/RC	External keyboard	Normally open terminal

PowerWadi – WADI VFD

Smart Power. Smarter Control.

0.75KW~37KW Control Terminal Location and Function Description

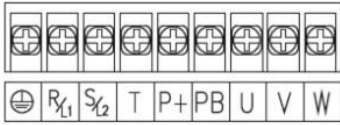

0.75-5.5KW

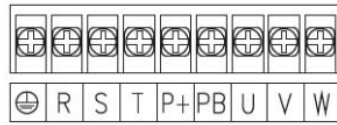

7.5-11KW

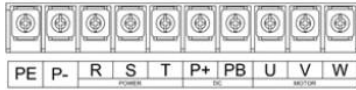

15-22KW

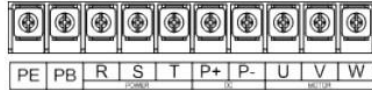

30-37KW

Terminal symbol	Terminal name and function description
PE,	Ground terminal
R, S, T L1, L2	Three-phase AC input terminal Single-phase AC input terminal
P+, PB	External braking resistor terminal
U, V, W	Three-phase AC output terminal

Keypad

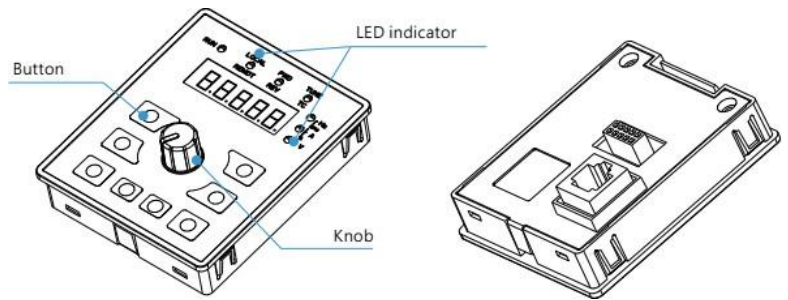
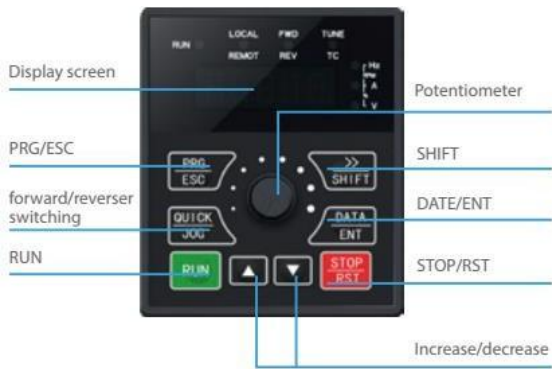

Terminal symbol	Terminal name and function description
PRG/ESC	To enter or exit setting mode
DATE/ENT	To confirm the selection/value in setting mode.
Increase/decrease	To increase/decrease the setting value.
SHIFT	In the shutdown display interface and operation display interface, the parameters to be displayed can be selected circularly; when modifying the parameters, the modification bit of the parameters can be selected.
RUN	In keyboard mode operation, used to run operation
STOP/RST	In the running state, pressing this key can be used to stop the running operation. When the fault alarm state is restricted by the function code P.04, all control modes can be used to reset the operation by this key.
Potentiometer	Adjust rate and frequency

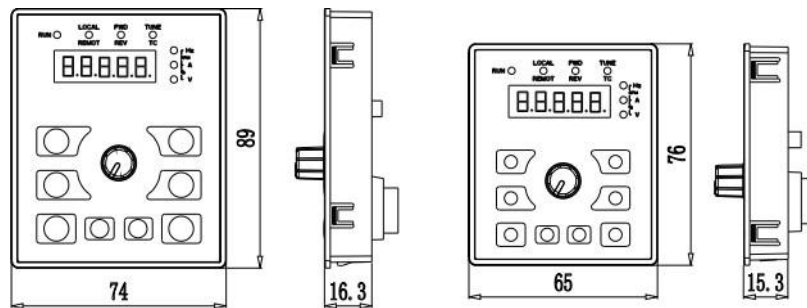

MINI model